

[CONTRIBUTION FROM THE CHEMICAL LABORATORY OF THE SCHOOL OF CHEMISTRY AND PHYSICS OF THE PENNSYLVANIA STATE COLLEGE]

PSEUDO BASES. III. THE SO-CALLED
METHYLPHENYLACRIDOL. THE ACTIVITY COEFFICIENTS
OF 5-PHENYL-10-METHYLACRIDINIUM HYDROXIDE
FROM SOLUBILITY MEASUREMENTS

BY JOHN G. ASTON AND CHARLES W. MONTGOMERY

RECEIVED JULY 25, 1931

PUBLISHED DECEMBER 10, 1931

Introduction

Hantzsch and Kalb¹ found that the conductivity of a mixture of 5-phenyl-10-methylacridinium sulfate and sodium hydroxide fell rapidly with the time and concluded from their results that the change was due to the

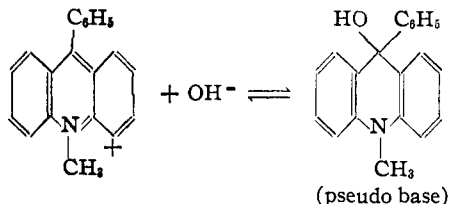

slow establishment of the equilibrium which they concluded was greatly in favor of the pseudo base, methylphenylacridol.

In the previous paper it was pointed out² that the experiments of Hantzsch and Kalb are capable of being explained in quite a different way. A graph of the results indicated that the fall in conductivity is due to the precipitation of the base 5-phenyl-10-methylacridinium hydroxide from solution. Throughout this paper, since we deal only with equilibrium conditions, we shall use the name 5-phenyl-10-methylacridinium hydroxide in referring to the pseudo basic system at equilibrium, treating the system, as a whole, as a single base. Preliminary experiments indicated that this base was highly ionized in aqueous solution.

The equilibria in other aqueous pseudo basic systems were shown to favor the most highly conjugated tautomer.² From the above view the equilibrium in the case of 5-phenyl-10-methylacridinium hydroxide is no exception to the general rule but if the interpretation which Hantzsch and Kalb placed upon their experiments is accepted, the theory falls down and a serious obstacle to any theory of pseudo basic behavior is presented.

Further evidence regarding the ionization of 5-phenyl-10-methylacridinium hydroxide has therefore been obtained. In the present paper are recorded activity coefficients, determined by solubility measurements in solutions of other electrolytes. They are those of a typical strong electrolyte.

¹ Hantzsch and Kalb, *Ber.*, **32**, 3109 (1899).

² Aston, *THIS JOURNAL*, **53**, 1448 (1931).

Experimental Method and Results

1. Preparation of Materials

5-Phenyl-10-methylacridinium Hydroxide.—5-Phenylacridine was methylated according to the method of Bernthsen³ by heating with methyl iodide at 100° for twelve to fourteen hours. The product was refluxed twice for three to four hours with 500 cc. of ether to dissolve any unchanged phenylacridine and crystallized twice from hot alcohol. The chloride was then made by shaking 11 g. of the iodide with 100 cc. of distilled water and an excess of silver chloride for twenty-four hours. The chloride solution, after dilution, was then slowly added to a dilute solution of sodium hydroxide (10% excess) in a carbon dioxide-free atmosphere, with continual stirring. The white hydroxide was then filtered. It was washed many times with conductivity water and dried, both operations being carried out in an atmosphere of carbon dioxide-free nitrogen. The compound melted sharply at 139°. This melting point was unchanged after three months' standing. Decker⁴ records 140°.

Added Salts.—Potassium chloride (Baker's Analyzed) was recrystallized and dried at 300° in an air-bath. It gave no alkaline reaction to phenolphthalein.

Barium chloride (Baker's Analyzed) was recrystallized and dried at 120° for twenty-four hours.

Conductivity water used for the solubility measurements had a specific conductance of $0.35\text{--}0.45 \times 10^{-6}$ ohm⁻¹ cm.⁻¹, at 25°. It was distilled from alkaline permanganate, the middle third being collected hot. This portion was redistilled through a quartz tube and the middle third collected cold. Carbon dioxide-free nitrogen was continually passed through the distillate to keep out carbon dioxide.

2. Apparatus

The apparatus used for analyzing the solutions was a Lemon-Brace spectrophotometer,⁵ mounted as a color analyzer. It is shown in Fig. 1. FN is the fixed nicol prism, MN the movable one. Two inside slits (IS) were placed in the telescope tube to narrow the field. The cell (C) was of the type used by Brode⁶ and was 10 cm. long. The cell holder (H) is a half section of iron pipe having two diaphragms (D) at the tube ends to eliminate stray light. By means of a converging lens (L), the light passing through the cell was brought to a focus directly in front of the slit. Two 200-watt 110-volt Mazda Daylight lamps operated in parallel served as light sources. These were mounted in rigid housings and the voltage across them was kept constant at 100 volts. The relative intensity of light transmitted through the cell was measured in terms of the light beam incident on the nicol prisms by reading the angle between them which equalized the two intensities.

3. The Solubility Measurements

Solutions of known concentration of 5-phenyl-10-methylacridinium chloride were prepared by dissolving the hydroxide in 0.01 *M* hydrochloric acid. By means of the spectrophotometer the ratio I/I_0 was determined for light of $\lambda = 4870$ Å. using the 10-cm. cell. (I and I_0 are the relative intensities transmitted through distilled water and the solution respec-

³ Bernthsen, *Ann.*, **224**, 28 (1884).

⁴ Decker, *J. prakt. Chem.*, **192**, 425 (1911).

⁵ (a) Ferry, "A Handbook of Physics Measurements," John Wiley and Sons, Inc., New York, 1926, p. 156; (b) Lemon, *Astrophys. J.*, **39**, 204 (1914).

⁶ Brode, *THIS JOURNAL*, **46**, 581 (1924).

tively.) In all cases an average of at least ten readings was taken. By plotting $-\log I/I_0$ against the concentration a curve was obtained from which the concentrations of unknown solutions could be read (Curve A, Fig. 2). Below a concentration of 1.4×10^{-4} moles per liter the curve is linear and Beer's law is obeyed

$$-\log I/I_0 = 0.229 \times 10^{-3} \times C \times l \quad (1)$$

where C is the concentration of 5-phenyl-10-methylacridinium hydroxide and l the length of the cell. Since in all the activity coefficient determinations the solubility never exceeded this value, the solubility ratio S/S_0 is

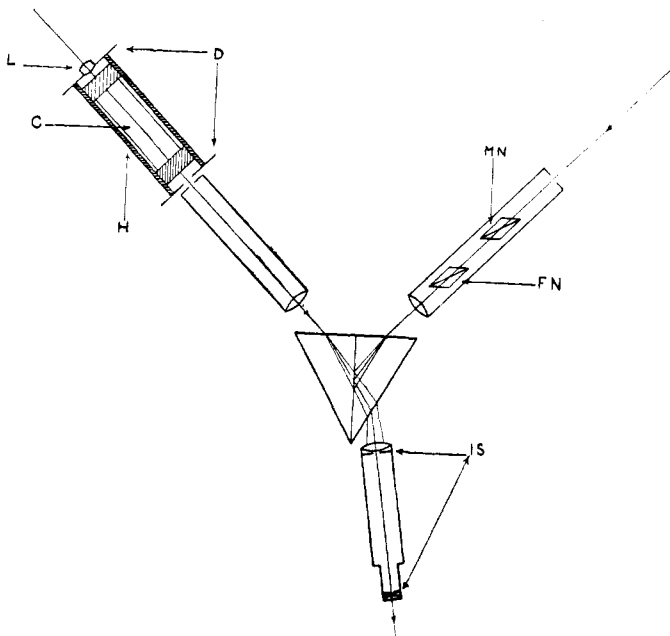

Fig. 1.—Diagram of the color analyzer.

independent of the curve. Experiment showed that potassium chloride did not change the absorption of solutions of 5-phenyl-10-methylacridinium hydroxide when added in amounts greater than those present in the solubility measurements. The concentration of excess acid had also no effect.

For the solubility measurements, flasks were made by drawing out the necks of 250-cc. round-bottomed, long-necked flasks to about half their original diameter. Each flask was then cleaned, well steamed out, dried and weighed. The weighed quantity of added salt was then introduced and the flasks were well swept out with carbon dioxide-free nitrogen and stoppered with soda-lime tubes. Approximately 0.3 g. of the hydroxide was quickly transferred from a nitrogen-filled desiccator to each flask and

roughly 100 cc. of freshly prepared conductivity water was run into each flask. The flasks were again stoppered, sealed at the constrictions and weighed. The flasks were then placed in the thermostat (temp., $25 \pm 0.05^\circ$, constant to 0.01°) and clamped at right angles to a rotating rod (20 r. p. m.). They were rotated in the thermostat for at least six days, as experiment showed that equilibrium was attained within this time.

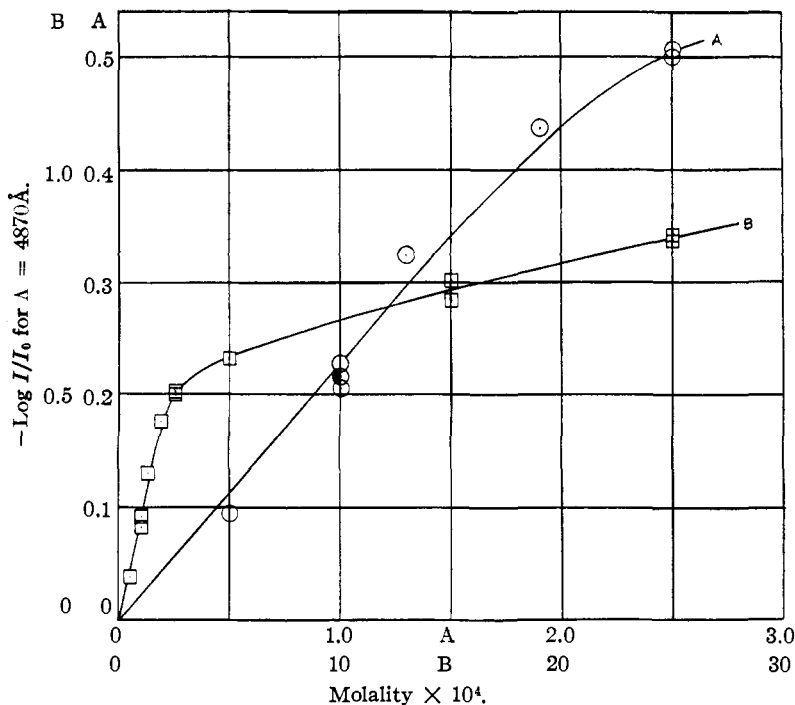

Fig. 2.—Curves used in the analysis of 5-phenyl-10-methylacridinium chloride solutions: points on Curve A, \odot (no added salt); \bullet ($0.26 M$ in KCl); points on Curve B, \square (no added salt).

After rotating, each flask was clamped in the thermostat and broken open. A wide glass tube was fitted over the neck, a joint being made by means of a rubber stopper at a point well below the break. This glass tube carried a stopper through which passed a soda-lime tube and the filter tube. The latter contained a wad of absorbent cotton at the end which extended to the bottom of the flask; the other end was connected to a suction flask. The solution was filtered into the suction flask by slight suction. Experiment showed that adsorption by the cotton was negligible. The suction flask was then weighed and the necessary amount of $0.1 M$ hydrochloric acid added to make the solution $0.01 M$ in acid. $-\log I/I_0$ values were determined by the spectrophotometer and the corresponding

concentration read from the analytical curve. This value was then corrected for the amount of acid added to obtain the true concentration of the saturated solution. In each case an average of at least ten spectrophotometer readings was taken.

4. Results

In calculating the results, the graphical method and equation of Brönsted and La Mer were employed.⁷

$$-\log f = \log S/S_0 - \log f_0 \quad (2)$$

where S_0 is solubility in otherwise pure water; S is solubility in presence of added salt; f_0 is activity coefficient in pure water and f is activity coefficient in presence of the added salt. The results of the solubility measurements are given in Table I.

TABLE I
SOLUBILITY AND ACTIVITY COEFFICIENTS OF 5-PHENYL-10-METHYLACRIDINIUM HYDROXIDE AT 25.00°

Nature of added salt	Molarity of added salt	Solubility, moles per 1000 g. $\times 10^4$	μ	$\sqrt{\mu}$	$\log S/S_0$	$-\log f$	f Found	f Calcd.
None	0.83	0.000083	0.0091	0.0000	0.0045	0.99	0.99
None82						
BaCl ₂	0.00296	.96	.0090	.095	.0652	.0697	.85	.90
KCl	.0388	.97	.0389	.197	.0697	.0742	.84	.79
KCl	.0399	1.10	.0400	.200	.127	.131	.74	.79
KCl	.0675	1.06	.0675	.260	.107	.112	.77	.74
KCl	.0739	1.15	.0739	.272	.146	.150	.71	.73
BaCl ₂	.0444	1.16	.133	.365	.148	.153	.70	.65
KCl	.138	1.29	.138	.372	.196	.200	.63	.65
KCl	.141	1.41	.141	.375	.233	.237	.58	.65

The nature and concentration of the added salts are given in columns 1 and 2, respectively. A plot of $\log S/S_0$ (col. 6) against the square root of the ionic strength, $\sqrt{\mu}$ (col. 5), was first made and the value of $\log f_0$ obtained by extrapolation. By equation 2, $-\log f$ was then calculated (col. 7) and the values plotted against $\sqrt{\mu}$ (Fig. 3). In col. 8 are given the values of f found. These are compared with the values calculated from the Debye-Hückel limiting slope equation

$$-\log f = 0.505 \sqrt{\mu} \quad (3)$$

for a strong electrolyte.⁷

The effect of ammonium chloride and sodium hydroxide on the solubility of the compound was also investigated. A very large increase in solubility was observed with the ammonium chloride, so that the analytical curve had to be greatly extended. For high concentrations of the chloride (above 0.0015 molal) a very unusual phenomenon was observed. The blue region of the spectrum was not only greatly decreased in intensity but was also

⁷ Brönsted and La Mer, THIS JOURNAL, 46, 555 (1924).

changed in shade. This was not characteristic of the instrument, as two spectrometers also gave the same effect. Furthermore, blue lines in the mercury and argon spectra when observed through the solution appeared greenish but were not displaced. This same effect was observed with solutions of other fluorescent substances, *e. g.*, fluorescein.⁸ In spite of the difference in shade, it was relatively simple to obtain *apparent* intensity matches which were reproducible with respect to time and observer. For

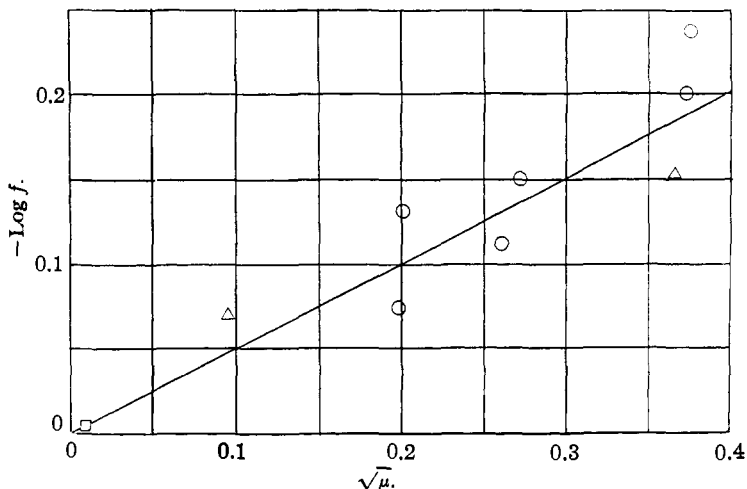

Fig. 3.—Activity coefficients of 5-phenyl-10-methylacridinium hydroxide: ○, added salt—KCl; △, added salt—BaCl₂; □, no added salt.

this reason, irrespective of the meaning of the analytical curve in the concentrated range (Curve B, Fig. 2), concentrations could be measured within 10%. The results on ammonium chloride are given in Table II.

TABLE II
SOLUBILITY OF 5-PHENYL-10-METHYLACRIDINIUM HYDROXIDE IN AMMONIUM CHLORIDE
AT 25.00°

Molality of NH ₄ Cl	Solubility Moles per 1000 g. × 10 ²	
	Found	Calcd.
0.0193	2.34	2.51
.0187	2.31	2.46

With 0.0027 *M* sodium hydroxide solution as solvent there was no observable color after the addition of hydrochloric acid to the saturated solution as in all the previous cases. The solubility was thus too small to measure.

Discussion of Results

The average deviation of the measured activity coefficients from those calculated from equation (3) is 5% and in only two cases does the deviation

⁸ Solutions of 5-phenyl-10-methylacridinium hydroxide exhibited a marked greenish fluorescence.

exceed 6%. The average deviation of the mean of the spectrophotometer readings corresponded to an error of 5.4% in the concentration when measuring concentrations of about 1×10^{-4} molal. This error is greater than the expected deviations from either the Debye-Hückel limiting slope law or the Lewis principle of ionic strength when dealing with a uni-univalent added salt at values of μ below 0.15.⁹ For this reason a line representing equation (3) has been drawn in Fig. 3 rather than a curve through the points, but it is obvious that such a curve would fuse into this theoretical line in the dilute solutions.

These results although only semiquantitative show conclusively that 5-phenyl-10-methylacridinium hydroxide is a strong electrolyte. We do not believe that it is possible at present or necessary to obtain results of a greater accuracy to further prove the point.

The results on the solubility in sodium hydroxide and ammonium chloride are self-explanatory. The theoretical values of the latter were calculated on the assumption that there was no interionic attraction, *i. e.*, that all the electrolytes were perfect solutes, using 1.81×10^{-5} as the basic dissociation constant of ammonium hydroxide,¹⁰ and assuming that 5-phenyl-10-methylacridinium hydroxide is completely ionized in aqueous solution. These results confirm the previous conclusions.

The concentration of pseudo base at equilibrium must, therefore, be negligible as was indicated in the previous paper.²

The data of Hantzsch are, then, apparently an example of slow rates of crystallization. Our results, however, show nothing regarding the nature of the compound in the solid state. Indeed, certain properties, *e. g.*, its low melting point, formation of ethers, etc.,¹¹ indicate that in the solid state the molecule might be in the pseudo basic form.

In conclusion we wish to express our thanks to Professor W. R. Ham and Mr. L. T. DeVore, colleagues in the Physics Department, for the loan of the spectrophotometer and for valuable suggestions regarding its use as a color analyzer.

Summary

1. The activity coefficients of the 5-phenyl-10-methylacridinium hydroxide pseudo basic system have been determined by solubility measurements in dilute solutions of potassium chloride and barium chloride. The values are those of a typical strong electrolyte within experimental error. The equilibrium concentrations of pseudo base are, therefore, negligible.
2. The solubilities in ammonium chloride and sodium hydroxide further show that the base is a strong electrolyte.

⁹ La Mer and Goldman, *THIS JOURNAL*, **51**, 2640 (1929).

¹⁰ "International Critical Tables," Vol. VI, p. 260.

¹¹ (a) Decker, *J. prakt. Chem.*, **45**, 195 (1891); (b) Decker, *Ber.*, **35**, 3072 (1902).

3. The interpretation placed upon their results by Hantzsch and Kalb appears to be erroneous.

STATE COLLEGE, PENNSYLVANIA

[CONTRIBUTION FROM CHEMICAL LABORATORIES OF NEW YORK UNIVERSITY]

TERNARY SYSTEMS. XI. MAGNESIUM IODATE, SODIUM IODATE AND WATER. XII. SODIUM IODATE, POTASSIUM IODATE AND WATER. XIII. POTASSIUM IODATE, POTASSIUM CHLORIDE AND WATER. XIV. POTASSIUM IODATE, POTASSIUM SULFATE AND WATER¹

BY ARTHUR E. HILL AND JOHN E. RICCI

RECEIVED AUGUST 1, 1931

PUBLISHED DECEMBER 10, 1931

In continuation of the study of three-component systems involving salts found in the Caliche of Chile, the following four systems have been investigated at 5, 25 and 50°. In addition to the solubility data there found, a brief discussion will be given of two points bearing upon all of the systems.

Anomalous Solubility Equilibria for Sodium Iodate and Potassium Iodate.—In an earlier paper² it was pointed out that satisfactory agreement for solubility at 25° approached from undersaturation and supersaturation could not be attained for sodium iodate even after long periods of agitation, even when care had been taken to insure that the salt had been completely hydrated before the solubility experiments were begun. Not only did the results from supersaturation and undersaturation fail to reach the same figure, but irregularities frequently were found of a magnitude many times that of the probable analytical error. It is to be added that potassium iodate, used in the present investigation, has also shown irregularities in solubility data, though of a much lesser amount. For this disturbing behavior of the two salts we have been unable to find an explanation in our own work. A publication from McBain and Kistler,³ appearing at nearly the same time as our publication upon sodium iodate, presents information which may contain the explanation for the behavior of these iodates. Subjecting a 0.33 *N* aqueous solution of potassium iodate to ultra-filtration under pressure through cellophane membranes, they found an increase in concentration in the unfiltered residue amounting to 12 to 16%, from which they feel justified in drawing the "remarkable conclusion that aqueous potassium iodate contains colloidal constituents." The presence of colloidal constituents in the solubility equilibrium would

¹ The material of this paper was presented by John E. Ricci in partial fulfillment of the requirements for the degree of Doctor of Philosophy at New York University.

² Hill and Donovan, *THIS JOURNAL*, **53**, 935 (1931).

³ McBain and Kistler, *J. Phys. Chem.*, **35**, 130 (1931).